

■ AC Power  
For Business-Critical Continuity™

## Liebert® GXT3

Compact UPS Systems for High Power Network Rack Applications  
5kVA ■ 6kVA ■ 10kVA



# Liebert GXT3, 5kVA-10kVA UPS Systems: Big Protection, Small Package

Today's converged networks require increased availability and reliability. This has created a need for higher density power protection systems that adapt to mixed load voltages and plug types, while remaining easy to install and maintain.

New IT technologies, such as VoIP and PoE, have greatly increased power demands. Unfortunately, as these requirements have risen, the amount of space available for your protected equipment and related power support systems has not.

## The Liebert Solution

Liebert GXT3 UPS meets the need for higher power capacities in small spaces. This true on-line double conversion UPS system is available in 5kVA – 10kVA models, and features integrated maintenance bypass, as well as optional extended battery runtime. Add support — Emerson Network Power Service — and it all equals greater power assurance and reliability.

Designed for use in either rack or tower configurations, all units offer the smallest available solutions for these power capacities — the 5 & 6kVA model at 230V output in 5U size, or the 10kVA unit 230V output in a 6U package.

To help meet the need for choosing a single supplier for global applications, 120/208V 50/60 Hz models are offered with UL markings.

## Communications For Power Monitoring And Control

Liebert GXT3 UPS offers a variety of communications options to provide the monitoring and control capabilities demanded by today's network computing systems. Operation can be monitored using:

- Liebert IntelliSlot Web Card provides SNMP and web-based monitoring and control of your UPS.
- Liebert MultiLink™ Automated System Shutdown Software
- Liebert Nform™ Monitoring System
- Liebert Universal Monitor And Remote Power Monitor Panels
- Third-Party Monitoring Systems



Liebert IntelliSlot Webcard provides SNMP and web-based management

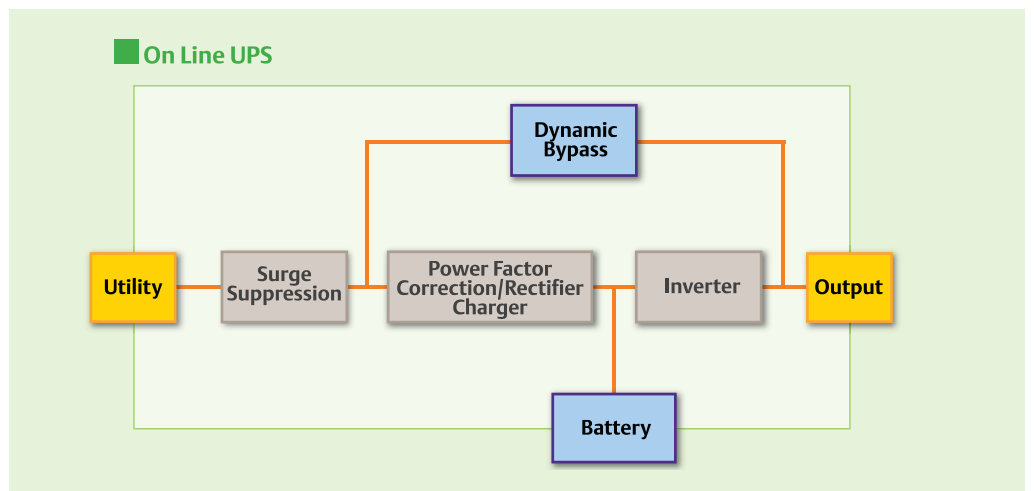

UPS operation and display panel can rotate 90 degrees, which provides upright viewing for users.



### Liebert GXT3 UPS Includes These Outstanding Features:

#### Flexibility:

- **Rack/tower configuration.** The versatile unit installs in either configuration, and includes a rotating LED display panel that conforms to the desired orientation.
- **Automatic frequency detection.** Detects and matches line input frequencies of either 60 or 50 Hz.
- **User replaceable hot-swappable internal batteries.** Provide three to six minutes of runtime at full load.
- **Additional runtime with additional battery cabinets.** UPS cabinet includes rear panel plug-and-play connections for optional battery cabinets. Cabinet sizes: 5kVA and 6kVA- 3U, 10kVA - 4U.
- **Liebert IntelliSlot™ communications port.** Utilizes Liebert IntelliSlot Web Card to provide SNMP and web-based monitoring and control of your UPS.
- **Includes Windows-based configuration program.** Allows various operating parameters to be adjusted and tests to be scheduled.
- **Built-in USB communications for use with Liebert MultiLink™ Automated Shutdown Software.** Allows you to monitor communication between the UPS and a server, and ensures a graceful unattended shutdown.
- **Built-in contact closure signals.** These are terminal blocks for dry contact relay signals.
- **Emergency Power Off (EPO).** Terminal connections for a normally open or normally closed emergency power off switch.

#### Higher Availability:

- **Wider input voltage window minimizes battery use.** Features a wide input voltage window that allows the UPS to support the critical load without having to transfer to battery, extending system availability for when battery back-up is truly needed.
- **Internal automatic and manual bypass.** Assures continuity of power to critical loads during system maintenance or in case of internal fault.
- **Self-diagnostics.** Automatically tests unit electronics and batteries. Designed to simplify maintenance and troubleshooting.
- **Lowest Total Cost Of Ownership:**
  - **Standard two-year replacement warranty.** Optional one-year and three year extensions available.
  - **Uses less rack space.** Leaves more room for network equipment.
  - **For longer service life.** Shields batteries from heat generating electronic components, enhancing battery life.
  - **Battery cutoff voltage** Automatically adjusts based on load, extending battery life by preventing over-discharge of batteries.

### Optional Service packages offer you complete peace of mind.

While today's smaller, rack-based UPS systems offer relatively trouble-free operation, the growing criticality of the systems they support has increased the cost of downtime. As a result, the need to maintain these smaller UPS systems is increasingly important.

**Extended Warranty** — choose choose additional 1 or 3 years warranty on top of 2 years standard warranty.

**Start-up** — On-site system start-up by a certified Emerson Network Power Customer Engineer.

**Preventive maintenance** — One visit per year with an option for two visits per year by a certified Emerson Network Power Customer Engineer.

**On-site service** — Should you experience a problem, we will dispatch a certified Emerson Network Power Customer Engineer to repair or replace your equipment. response guaranteed.

## 5 or 6kVA Of True On-Line Power In A Compact 5U Package

Liebert GXT3 5 & 6kVA models are true on-line UPS systems that provide internal batteries. They are an ideal fit for applications where the power requirements are demanding — but rack space is limited — delivering 5kVA (4kW) or 6kVA (4.8kW) of power in a single 5U size cabinet. This cabinet size is well suited for installations such as network closets or small data centers.

### Adaptable Design

For installation flexibility, the Liebert GXT3 5 & 6kVA models come with power distribution units, or POD, allowing continuous operation for connected equipment during UPS maintenance or replacement. The POD contains 2x IEC-C19 receptacles for blades servers or high-end networking switches, and 6x IEC-C13 receptacles.

### Higher Availability

- Provides utility power to attached equipment when switched to maintenance bypass mode.
- Allows UPS maintenance or replacement of the UPS without discontinuing power to critical equipment.

### Lowest Total Cost Of Ownership

- Assures system uptime during maintenance activities.

### Bundled solution

- Liebert GXT3 5, 6, and 10KVA come with POD pre-installed.
- Affordable method of providing bypass.



■ 5 & 6 kVA Model shown in rack mount position



■ 6 kVA Model shown in tower position with optional battery cabinet

## 10kVA Of Power In Just 6U Of Space

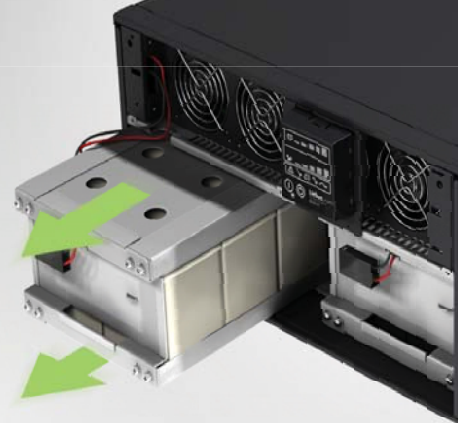

The internal battery packs are hot-swappable, and user replaceable. The unit also supports up to four external battery cabinets for extended run time.



■ 10 kVA Model shown in rack mount position



■ 10 k VA Model shown in tower position with optional battery cabinet

**This Liebert GXT3 10kVA unit offers a flexible solution for protecting rack-mount equipment, including VoIP and PoE. Especially designed for use with the new generation of high power switches, this compact UPS system packs 10kVA (9kW) of power into a 6U rack/tower package with flexible output voltage and bundled output distribution and maintenance bypass. The UPS includes built-in, user-replaceable batteries for up to three minutes of runtime at full load.**

### Adaptable Design

The UPS has output power factor 0.9. That is, 10kVA model provides 9kW output power. The unit features integrated internal manual and automatic maintenance bypass, power module, battery modules and auto detection of extended battery cabinets.

The standard 10kVA model includes terminal blocks for hardwired connections of both input and output. The bundled power distribution module provides 4x IEC-C19 receptacles for blade servers or high-end networking switches and 4x IEC-C13 receptacles.

### Hot-Swappable Operation

The Liebert GXT3 10kVA unit features three bays for one power module and two battery modules. The chassis contains a bypass switch that allows all modules to be removed without powering down the connected load.

# Product Specifications

## UPS specifications—5, 6 and 10 kVA models

Model Number	GXT3-5000RT230	GXT3-6000RT230	GXT3-10000RT230
Rating (VA / W)	5000VA / 4000W	6000VA / 4800W	10000VA / 9000W
<b>Physical Dimensions</b>			
Unit: W x D x H (mm) / (in)	430 x 574 x 217 / 16.9 x 22.4 x 8.5		430 x 581 x 261 / 16.9 x 22.9 x 10.3
Size in Rack (RU)	5U		6U
Shipping: W x D x H (mm) / (in)	745 x 530 x 516 / 29.3 x 20.9 x 20.3		530 x 745 x 563 / 20.9 x 29.3 x 22.2
<b>Weight</b>			
Unit (kg) / (lb)	60 / 132.2		70 / 154.3
Shipping (mm) / (in)	71 / 156.5		92 / 202.8
<b>Input AC Parameters</b>			
Operating Frequency	50 or 60Hz Nominal (factory default = 50)		
Factory Default	230VAC		
User-Configurable	220 / 230 / 240VAC		
Operating Voltage Range (without battery operation)	176 to 280VAC		
Maximum Allowable	280VAC		
Input Frequency (without battery operation)	40 to 70Hz		
Input Power Connection	PD2-CE6HDWRMBS Standard	PD2-CE10HDWRMBS Standard	
<b>Output AC Parameters</b>			
Factory Default	230VAC		
Output Connections	PD2-CE6HDWRMBS Standard	PD2-CE10HDWRMBS Standard	
Frequency	50Hz or 60Hz Nominal		
Waveform	Sinewave		
Main Mode Overload	> 200% for 5 cycles; 151 to 200% for 1 seconds; 131 to 150% 10 seconds; 105 to 130% 1 minute		
<b>Battery Parameters</b>			
Type	Valve-regulated, non-spillable, lead acid		
Quantity	20 x 12V		
Recharge Time (internal batteries)	3 hrs to 90% capacity after full discharge into 100% load		
<b>Bypass Protection Limits</b>			
Disable Bypass Operation	If input voltage exceeds $\pm 15\%$ of the nominal voltage		
Re-Enable Bypass Operation	If input voltage returns to within $\pm 10\%$ of nominal output voltage		
Disable Bypass Operation	When the input frequency prevents synchronous operation		
<b>Environmental</b>			
Operating Temperature ( $^{\circ}\text{C}$ ) ( $^{\circ}\text{F}$ )	0 to 40 (32 to 104)		
Storage Temperature	-15 to 50 (5 to 122)		
Relative Humidity	0 to 95%; non-condensing		
Operating Elevation	Up to 1000m (3281 ft) at 30 $^{\circ}\text{C}$ (86 $^{\circ}\text{F}$ ) without derating		
Audible Noise	< 55 dBA at 1 meter from the rear; < 50 dBA at 1 meter from the front or sides		
<b>Agency Approvals</b>			
Safety	IEC62040-1:2008 version		
EMI / EMC	IEC / EN / AS 62040-2 2nd Ed (Cat 2 – Table 6)		
ESD	EN61000-4-2, Level 4, Criteria A		
Radiated Susceptibility	EN61000-4-3, Level 3, Criteria A		
Electrical Fast Transient	EN61000-4-4, Level 4, Criteria A		
Surge Immunity	EN61000-4-5, Level 3, Criteria A		
Transportation	ISTA Procedure 1A		

## Power distribution specifications

Model Number	PD2-CE6HDWRMBS	PD2-CE10HDWRMBS
Amp Rating (Amps)	32	63
Input Power Connection	3-Wire Hard-Wired; 6-10mm <sup>2</sup> (8-10AWG)	
Output Power Connection	3-Wire Hard-Wired, 6-10mm <sup>2</sup> (8-10AWG)	
Includes	Two IEC320 C19 16A/250V Sockets Eight C13 10A/250V Sockets Manual Bypass Switch with Indicator Lamps	Four IEC320 C19 16A/250V Sockets, Four C13 10A/250V Sockets Manual Bypass Switch with Indicator Lamps
Input Branch Circuit Breaker, Supplied by User	32A	63A

## External battery cabinet specifications

Model Number	GXT3-240VBATTCE	GXT3-240RTVBATT
Used with UPS Model	GXT3-5000RT230 ; GXT3-6000RT230	GXT3-10000RT230
<b>Physical Dimensions</b>		
Unit (with bezel): W x D x H (mm) / (in)	430 x 570 x 148 / 16.9 x 22.4 x 5.8	430 x 577 x 173 / 16.9 x 22.7 x 6.8
Shipping: W x D x H (mm) / (in)	530 x 745 x 407 / 20.8 x 29.3 x 16	530 x 745 x 475 / 20.8 x 29.3 x 18.7
<b>Weight</b>		
Unit (kg) / (lb)	50.4 / 111	52.6 / 116
Shipping (kg) / (lb)	54 / 119	76 / 167.6
<b>Battery Parameters</b>		
Type	Valve-regulated, non-spillable, lead acid	
Quantity	1 x 20 x 12V	
<b>Agency Approvals</b>		
Safety	IEC62040-1:2008 version	
Transportation	ISTA Procedure 1A	

## Run Time, Minutes, for Load, Watts

Number of Batteries	UPS Model	1400	1800	2200	2600	3000	3400	3800	4200	4600	100% load (min)	100% load (W)
Internal Battery	GXT3-5000RT230	28	18	14	11	9.5	7.5	6.5	-	-	6	4000
	GXT3-6000RT230	28	18	14	11	9.5	7.5	6.5	5	4	4	4800
Internal Battery + 1 External Battery Cabinet	GXT3-5000RT230	56	36	28	22	19	15	13	-	-	12	4000
	GXT3-6000RT230	56	36	28	22	19	15	13	10	8	7	4800
Internal Battery + 2 External Battery Cabinets	GXT3-5000RT230	84	54	42	33	28.5	22.5	19.5	-	-	18	4000
	GXT3-6000RT230	84	54	42	33	28.5	22.5	19.5	15	12	10	4800
Internal Battery + 3 External Battery Cabinets	GXT3-5000RT230	112	72	56	44	38	30	26	-	-	24	4000
	GXT3-6000RT230	112	72	56	44	38	30	26	20	16	14	4800
Internal Battery + 4 External Battery Cabinets	GXT3-5000RT230	140	80	70	55	47.5	37.5	32.5	-	-	30	4000
	GXT3-6000RT230	140	80	70	55	47.5	37.5	32.5	25	20	18	4800

Number of Batteries	UPS Model	3000	3600	4200	4800	5400	6000	6600	7200	7800	8400	9000	100% load (W)
Internal Battery	GXT3-10000RT230	19	14.5	11.5	10	8.5	7	6	5	4	3.5	3	9000
Internal Battery + 1 External Battery Cabinet	GXT3-10000RT230	38	29	23	20	17	14	12	10	8	7	6	9000
Internal Battery + 2 External Battery Cabinets	GXT3-10000RT230	57	43.5	34.5	30	25.5	21	18	15	12	10.5	9	9000
Internal Battery + 3 External Battery Cabinets	GXT3-10000RT230	76	58	46	40	34	28	24	20	16	14	12	9000
Internal Battery + 4 External Battery Cabinets	GXT3-10000RT230	95	72.5	57.5	50	42.5	35	30	25	20	17.5	15	9000

## Rear panel specifications

### Liebert GXT3 5kVA & 6kVA

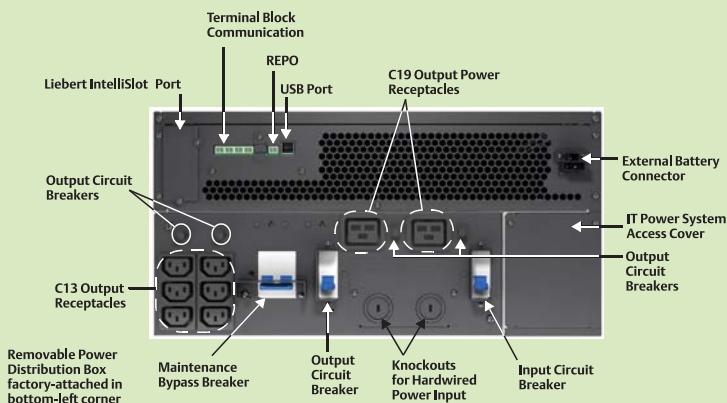

### Liebert GXT3 10kVA

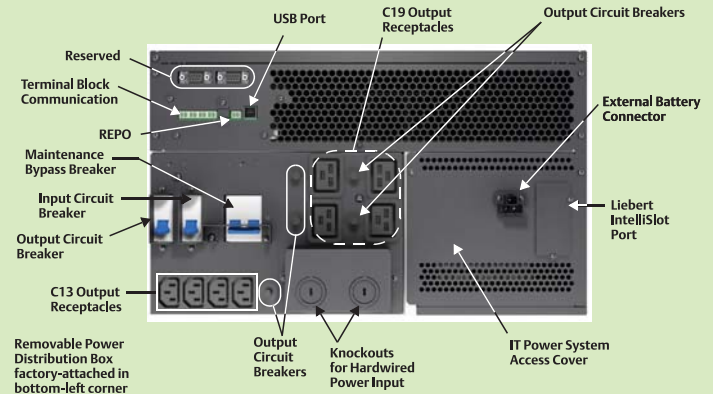

Emerson Network Power, a business of Emerson (NYSE:EMR), is the global leader in enabling *Business-Critical Continuity™* from grid to chip for telecommunication networks, data centers, health care and industrial facilities. Emerson Network Power provides innovative solutions and expertise in areas including AC and DC power and precision cooling systems, embedded computing and power, integrated racks and enclosures, power switching and controls, monitoring, and connectivity. All solutions are supported globally by local Emerson Network Power service technicians. Liebert AC power, precision cooling and monitoring products and services from Emerson Network Power deliver *Efficiency Without Compromise™* by helping customers optimize their data center infrastructure to reduce costs and deliver high availability.

#### Emerson Network Power Asia

**Australia**  
T: 1800-065345  
F: 61-2-97438737

**Pakistan**  
T: 92-42-36622526 to 28  
F: 92-42-36622530

**Indonesia**  
T: 62-21-2513003  
F: 62-21-2510622

**Philippines**  
T: 63-2-7207400  
F: 63-2-6203693

**Japan**  
T: 81-3-54038594  
F: 81-3-54032924

**Singapore**  
T: 65-64672211  
F: 65-64670130

**Korea**  
T: 82-2-34831500  
F: 82-2-5927883

**Thailand**  
T: 66-2-6178260  
F: 66-2-6178277 to 78

**Malaysia**  
T: 603-78845000  
F: 603-78845188

**Vietnam**  
T: 84-4-37628908  
F: 84-4-37628909

**New Zealand**  
T: 64-3-3392060  
F: 64-3-3392063

While every precaution has been taken to ensure the accuracy and completeness of this literature, Emerson Network Power assumes no responsibility and disclaims all liability for damages resulting from use of this information or for any errors or omissions.

Emerson, Business-Critical Continuity and Emerson Network Power are trademarks of Emerson Electric Co. or one of its affiliated companies.  
© 2012 Emerson Electric Co.

All rights reserved throughout the world. Specifications subject to change without notice.

#### Emerson Network Power.

The global leader in enabling *Business-Critical Continuity™*.

- AC Power
- Embedded Computing
- Outside Plant
- Connectivity
- Embedded Power
- Power Switching & Controls
- DC Power
- Infrastructure Management & Monitoring
- Precision Cooling

#### EmersonNetworkPower.com

- Racks & Integrated Cabinets
- Services
- Surge Protection